

***This modular buoy GBM 1400 – 0.7P, 1400mm in diameter, volume of 700L, is intended for the temporary beaconing. It can easily be equipped with a day mark and a colour spar specific to a particular beaconing (replacement of a lost mark, wreck marking).***

**This modular buoy includes:**

- 2 half PE float
- 1 monobloc structure of laminated polyester

**The structure includes:**

- A « spar » part, section 400x400mm and 3000mm in height, to accommodate and support the equipment. It is covered with a PVC envelope whose colour corresponds to the beaconing mark.
- A strap in galvanized steel at the float level to stop the horizontal and vertical motion of the float.
- A “lower” part containing the anchorage eye and the ballast in concrete to offer stability and to maintain the buoy in vertical position on land.

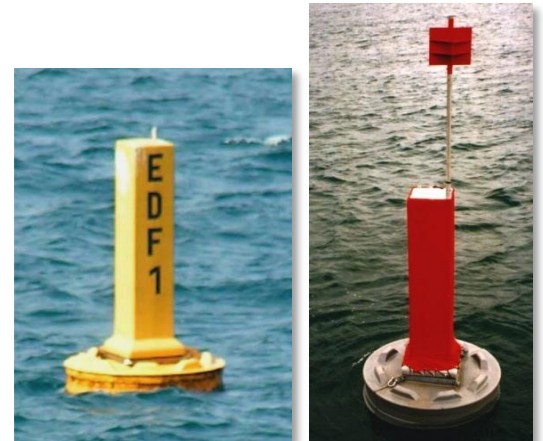

The float is made of rotomoulded medium density polyethylene, stained in the mass and UV resistant. The polyethylene colour is in conformance with IALA recommendations. The float is filled with polystyrene foam in order to guarantee the buoy buoyancy even in case of damage of the polyethylene envelope. The two half floats are tightened by a strap in galvanized steel

**Buoy features**

- 100% recyclable
- Low maintenance
- Easily storage
- Fast mooring

**Optional equipment**

- Top mark
- LED self contained lantern

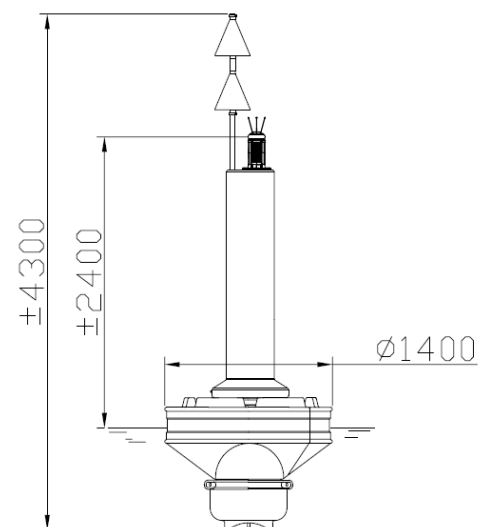

**Buoy specifications**

Diameter	1400mm
Volume	700L
Reserve buoyancy	0.3m <sup>3</sup>
Mass	395kg
Focal plane	2400mm
Draught	773mm
Height of superstructure	3081mm

**A PVC envelope to offer 9 types of beaconing**

- Portside/starboard side
- South cardinal/north/east/west
- Isolated danger
- Wreck Emergency Marking (Yellow and Blue)
- Special Mark